

Put away your knives and pliers!

PermOseal[®]

StretchFit

PIPE FLASHING



*StretchFit seal fits
1.5" - 2" and
3" - 4"
vent pipe sizes*

*The new
PermOseal[®]
StretchFit
requires no
adjustment, no
cutting and no
tearing!*

- UV and Extreme Cold Resistant
- Built in water deflectors
- Fits roof pitches from 2/12 to 12/12
- Patent Pending

MODEL:
551222
1.5"-2"
Pipe Sizes

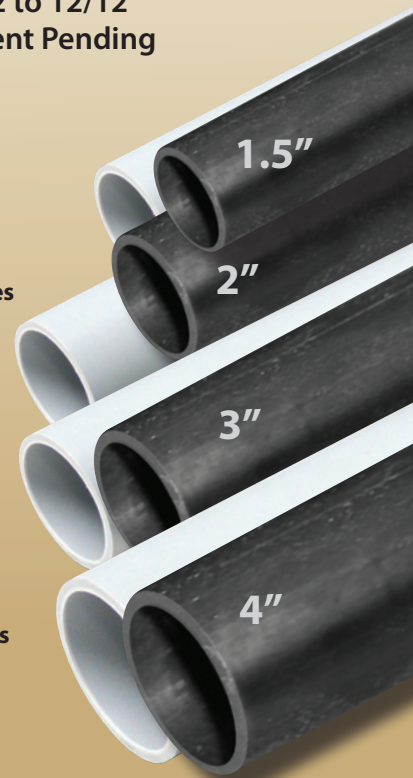

MODEL:
551224
3"-4"
Pipe Sizes

*The only flashing available
in a selection of colors.*



BL - Black

G - Green

WW - Weatherwood

W - White

BR - Brown

GR - Gray

duraflo.com

WE KNOW VENTILATION

by **canplas[®]**

an *Aliaxis* company

PermOseal®

StretchFit

PIPE FLASHING

The new PermOseal® StretchFit flashing by Duraflo® is a breakthrough in flashing seal technology.

Our newly engineered material can stretch beyond 200% to accommodate a wide variety of pipe sizes. Installers no longer have to carry multiple size flashings or pull and tear inferior materials risking poor pipe seals. With the 1.5" - 2" or the 3" - 4" StretchFit you simply push the flashing opening over the vent pipe, attach the flange to the roof and install the shingles. No adjustment to the product is required meaning less time spent during installation and a perfect seal every time.

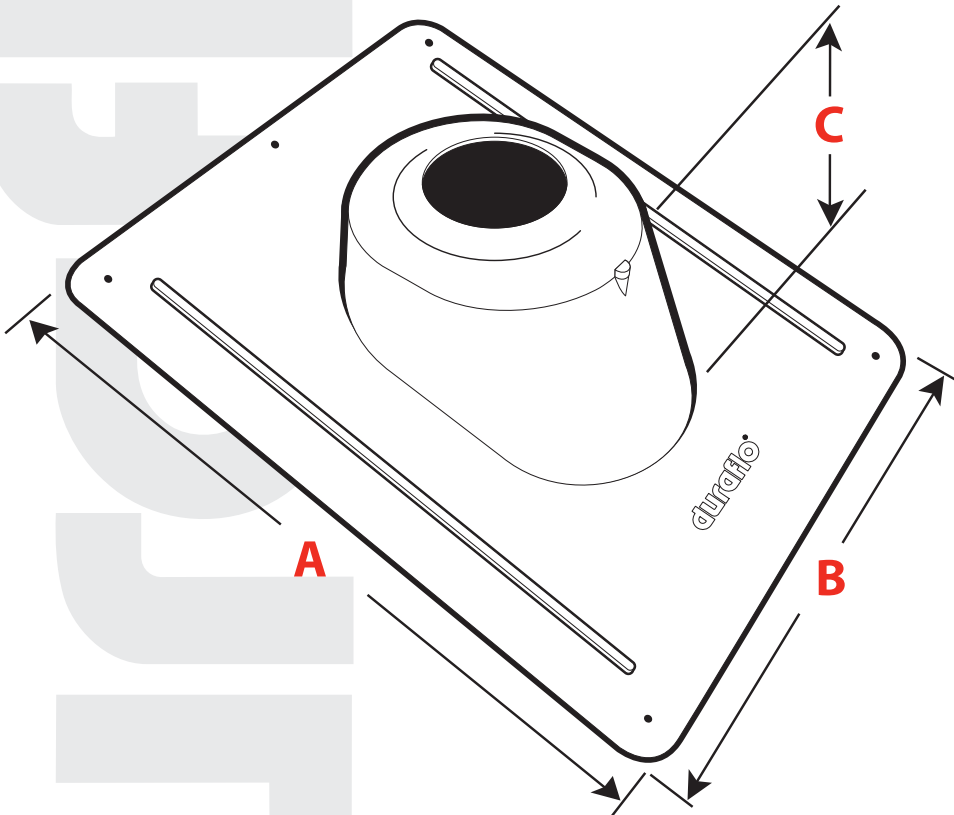

Dimensions:

MODEL: 551222
1.5"-2" Pipe Size

A: 15"
B: 13"
C: 3 1/2"

MODEL: 551224
3"-4" Pipe Size

A: 18"
B: 16 1/4"
C: 4 1/2"

COLOR	PART #	CTN. QTY.	WT.CTN. (LBS.)
PIPE SIZE 1.5" to 2"			
Black	551222BL	12	6
PIPE SIZE 3" to 4"			
Black	551224BL	12	9

Colors available - See front for color codes



CANADA

Canplas Industries Ltd.
P.O. Box 1800, 500 Veterans Dr.
Barrie, Ontario
Canada L4M 4V3
Tel: (705) 726-3361
Fax: (705) 726-8991
Toll Free: 1-800-461-5300

Canplas Industries Ltd.
11408 - 163rd Street
Edmonton, Alberta,
Canada T5M 3T3
Tel: (780) 451-3206
Fax: (780) 452-0536
Email: prairie.sales@canplas.com

Canplas Industries Ltd.
9489 - 200 Street, Unit 201
Langley, B.C.
Canada V1M 3A7
Tel: (604) 455-0432
Fax: (604) 455-0452
Email: bc.sales@canplas.com

USA

Canplas LLC
11402 East 53rd Ave., Suite 200
Denver, Colorado
U.S.A. 80239
Tel: (303) 373-1918
Fax: (303) 373-1923
Toll Free: 1-888-461-5307

E-mail: duraflo@canplas.com
www.duraflo.com

canplas®

an OAliaxis company