

# Bathroom Exhaust **VENT**

by **duraflo**<sup>®</sup>

**Stair step ribs which funnel water out, even in the heaviest rain**

- **Excellent UV Performance**
- A molded screen that will not become dislodged leaving openings for insects or pests
- The unique molded screen prevents birds from nesting
- Flexible flange which will not crack on installation, even in extreme cold
- Attractive low profile styling
- Available in Black, Brown, Weatherwood, Gray, Green and White
- CSA approved
- Patent pending design

Molded screen prevents insect and bird nesting

With & without internal flapper options available

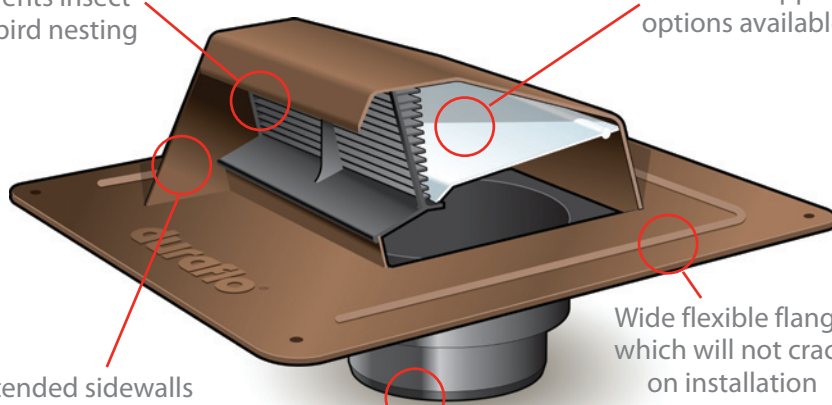

Extended sidewalls prevent crosswind water penetration

Wide flexible flange which will not crack on installation

With & without collar options available



**duraflo**.com  
WE KNOW VENTILATION

[www.duraflo.com](http://www.duraflo.com)

CAN: 1-800-461-1771 USA: 1-888-461-5307

**canplas**<sup>™</sup>

an *O*Aliaxis company

# Bathroom Exhaust **VENT** by duraflo®



Width:  
11" x 13"

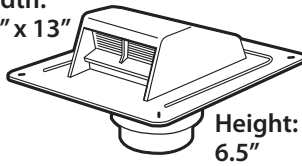

Height:  
6.5"

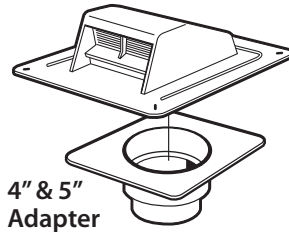

4" & 5"  
Adapter

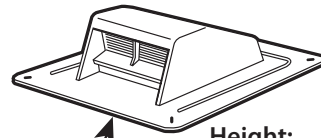

Throat Opening:  
5-3/4" x 5-3/8"

Height:  
3"

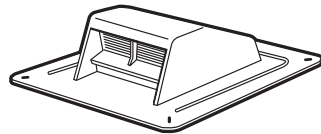

Height:  
3.5"

## BATHROOM EXHAUST VENT - Flapper & Attached Collar

DESCRIPTION	PART #	CTN. QTY.	WT.CTN. (LBS.)
Black	6011BL	6	7
Brown	6011BR	6	7
Grey	6011G	6	7
Green	6011GN	6	7
White	6011W	6	7
Weatherwood	6011WW	6	7

## BATHROOM EXHAUST VENT - Flapper & Unattached Collar

DESCRIPTION	PART #	CTN. QTY.	WT.CTN. (LBS.)
Black	6010BL	4	5
Brown	6010BR	4	5
Grey	6010G	4	5
Green	6010GN	4	3
White	6010W	4	3
Weatherwood	6010WW	4	5

## BATHROOM EXHAUST VENT - With Flapper Only

DESCRIPTION	PART #	CTN. QTY.	WT.CTN. (LBS.)
Black	6008BL	4	3
Brown	6008BR	4	3
Grey	6008G	4	3
Green	6008GN	4	3
White	6008W	4	3
Weatherwood	6008WW	4	3

## BATHROOM EXHAUST VENT - Without Flapper

DESCRIPTION	PART #	CTN. QTY.	WT.CTN. (LBS.)
Black	6009BL	4	3

## ADAPTER COLLAR - For Bathroom & Dryer Exhaust Vents

DESCRIPTION	PART #	CTN. QTY.	WT.CTN. (LBS.)
Black	6010-1BC	8	2

Attaches any 4" or 5" duct or pipe to Duraflo Bathroom Exhaust Vent or Roof Dryer Vent



## Duraflo Continues to Design Better Exhaust Vents

We selected a group of roofers, builders and architects to ask the question - "What do you need in ventilation products?". The answer was simple and clear - "Make an attractive, quality exhaust vent for bathroom fans that won't chatter in the wind and, of course, make it weatherproof".

The new Duraflo exhaust vent comes in a full selection of colors with low profile styling and quiet, consistent performance. Our unique flapper prevents chattering while our deep grill design prevents even the worst rain gust from entering. Duraflo, developing products that meet your needs.

### CANADA

**Canplas Industries Ltd.**  
P.O. Box 1800, 500 Veterans Dr.  
Barrie, Ontario  
Canada L4M 4V3  
Tel: (705) 726-3361  
Fax: (705) 726-8991  
Toll Free: 1-800-461-5300

**Canplas Industries Ltd.**  
11408 - 163rd Street  
Edmonton, Alberta,  
Canada T5M 3T3  
Tel: (780) 451-3206  
Fax: (780) 452-0536  
Email: prairie.sales@canplas.com

**Canplas Industries Ltd.**  
9489 - 200 Street, Unit 201  
Langley, B.C.  
Canada V1M 3A7  
Tel: (604) 455-0432  
Fax: (604) 455-0452  
Email: bc.sales@canplas.com

### USA

**Canplas LLC**  
11402 East 53rd Ave., Suite 200  
Denver, Colorado  
U.S.A. 80239  
Tel: (303) 373-1918  
Fax: (303) 373-1923  
Toll Free: 1-888-461-5307

E-mail: [duraflo@canplas.com](mailto:duraflo@canplas.com)  
[www.duraflo.com](http://www.duraflo.com)

**canplas®**

an OAliaxis company